

Square 75 tunnel

art. nr. **GSQ.1040**



Pijpdiameter (mm)
Pipe diameter (mm)
Diamètre buse (mm)
Abgasstutzen (mm)



Gewicht (kg)
Weight (kg)
Poids (kg)
Gewicht (kg)



Binnenwerk vermiculiet
Vermiculite panels inside
Intérieur vermiculite
Innenbekleidung Vermiculiet



Externe luchttoevoer
External air supply
Prise d'air extérieure
Externer Luftanschluss



Efficiëntie
Efficiency
Efficacité
Effizienz



Vermogen output (kW)
Capacity output (kW)
Puissance output (kW)
Leistung output (kW)



Bovenaansluiting
Connection top
Raccordement dessus
Anschluss oben

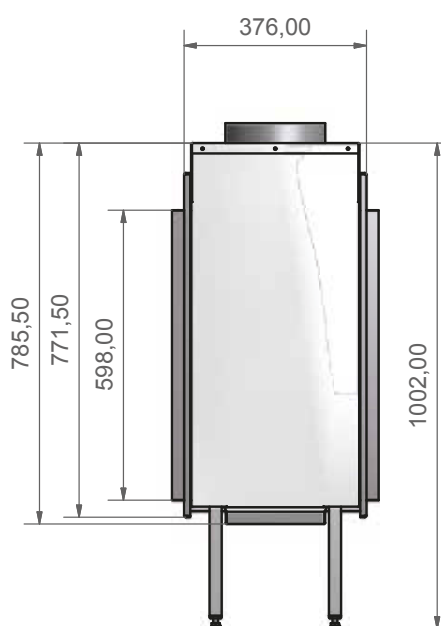
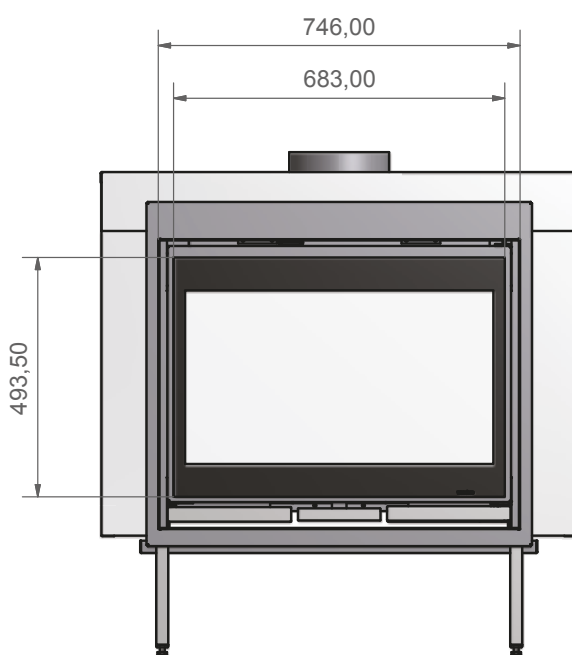
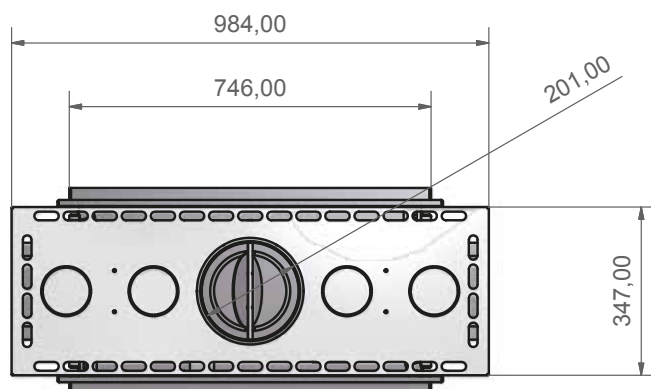

wanders
fires & stoves

Wanders fires & stoves | Tel: +31(0)315 - 386 414
Amtweg 4 | Fax: +31 (0)315 - 386 201
7077 AL NETTERDEN | info@wanders.nl
The Netherlands | www.wanders.nl