



Operating manual

Ivy 2.0 945027



AUSTROFLAMM

www.austroflamm.com

Operating manual
06/07/2022

Version: 1.0

LEGAL NOTICES

Owner and publisher
AUSTROFLAMM GMBH
Austroflamm-Platz 1
A- 4631 Krenglbach
Tel: +43 (0) 7249 / 46 443
www.austroflamm.com
info@austroflamm.com

Edited by: Olivera Stojanovic

Illustrations: Konstruktion

Text: Technical department (Austroflamm)

Copyright

All Rights reserved. The contents of these instructions may be reproduced or distributed only with the consent of the publisher! Printing, spelling and typographical errors reserved.

Contents

1	General information	5
1.1	Copyright.....	5
2	Purpose of the manual	6
2.1	Storing the manual	6
2.2	Structure of the manual.....	6
2.3	Representations used.....	6
2.4	Version control.....	6
2.5	Abbreviations	7
3	Safety	8
3.1	Importance of the safety instructions	8
3.2	Warning of sources of danger	8
3.2.1	General safety instructions	8
3.2.2	Special types of danger and personal protective equipment	9
4	Product overview	10
4.1	Intended use	10
4.2	Identification of the product.....	10
4.3	Energy label	12
4.4	Positioning of the nameplates	12
5	Technical data	13
5.1	Technical data according to Regulation (EU) 2015/1185 and delegated Regulation (EU) 2015/1186	13
5.2	General specifications.....	15
5.3	Data for the chimney/flue dimensioning	15
6	Transport, handling and storage	16
6.1	Transportation.....	16
6.2	Transport brackets.....	16
6.3	Storage.....	17
7	Requirements at the installation location	18
7.1	Safety distances to be observed.....	18
7.2	Combustion air	18
7.3	Chimney requirements	18
7.4	Floor load-bearing capacity	18
7.5	Floor condition.....	18
7.6	Room of installation.....	18
8	Fuel material/-quantity	19
8.1	Fuel.....	19
8.2	Fuel quantity.....	21
9	Installation	22
9.1	Risks and dangers.....	22
9.2	Execution	22
9.2.1	Rearranging the flue pipe connection	22

9.2.2	Installing the HMS.....	24
9.2.3	Mounting the Keramott.....	25
9.2.4	Mounting the base	25
9.2.5	Mounting the side box.....	26
9.2.6	Installing the log drawer	27
9.2.7	Mounting the external air connection at the rear	28
10	Settings.....	30
10.1	Adjusting the door	30
10.2	Adjusting the door spring	31
11	Commissioning.....	32
11.1	Initial Commissioning.....	32
11.2	Balanced Flue Operation.....	32
12	Operation.....	33
12.1	Before heating up.....	33
12.2	Making fire correctly.....	33
12.3	Heating in the transition period.....	34
13	Maintenance	35
13.1	Changing the seal on the door	35
14	Cleaning	36
14.1	Cleaning the stove, flue gas ducts and flue pipe	36
14.2	Emptying the ash box	36
14.3	Cleaning the door window	38
14.4	Cleaning surfaces	38
15	Help.....	39
15.1	Firebox lining	40
15.2	What to do in the event of a chimney fire.....	40
15.3	What to do in the event of faults.....	40
16	Accessories	41
17	Spare parts.....	42
18	Dismantling.....	45
18.1	Removing the rear panel	45
18.2	Removing the door.....	46
19	Disposal.....	47
20	Guarantee / warranty	49
21	Data processing	50
22	Start up log	51
23	Service Report	52

1 General information

You have decided in favor of an Austroflamm stove.

Congratulations on your decision and thank you for your trust.

Correct operation and care are essential for trouble-free operation and long service life.

The information in this manual is of a general nature. National and European standards, local and building regulations, together with fire regulations must be complied with.

Read these instructions through carefully before installation and operation. No liability or warranty claims apply for damage incurred by failure to follow this manual.

Please observe the instructions in the individual sections.

This manual is a component part of the stove. It includes all the important information for both the dealer and the customer.

Personally hand over this manual to the owner of the stove together with an introduction to the system (heating operations).

In the following list we give you an overview of which sections are important for whom:

Dealer	End customer
Complete instructions	General information [▶ on page 5]
	Purpose of the manual [▶ on page 6]
	Safety [▶ on page 8]
	Product overview [▶ on page 10]
	Technical data [▶ on page 13]
	Requirements at the installation location [▶ on page 18]
	Fuel material/-quantity [▶ on page 19]
	Settings [▶ on page 30]
	Commissioning [▶ on page 32]
	Operation [▶ on page 33]
	Maintenance [▶ on page 35]
	Cleaning [▶ on page 36]
	Help [▶ on page 39]
	Accessories [▶ on page 41]
	Spare parts [▶ on page 42]
	Dismantling [▶ on page 45]
	Disposal [▶ on page 47]
Guarantee / warranty [▶ on page 49]	
Data processing [▶ on page 50]	
Service Report [▶ on page 52]	

1.1 Copyright

All Rights reserved. The contents of these instructions may be reproduced or distributed only with the consent of the publisher! Printing, spelling and typographical errors reserved.

2 Purpose of the manual

This manual is a component part of the stove and is intended to contribute to the stove being safely installed and maintained.

TIP

Please read this manual before using the stove for the first time.

2.1 Storing the manual

Store this manual in case you need it. A current version of the manual can be found online at our homepage www.austroflamm.com.

2.2 Structure of the manual

The table of contents can be found on page 3.

Illustrations in this manual may differ from the delivered product.

2.3 Representations used

The following representations are used in this manual:

Steps with mandatory adherence to the sequence

✓ Prerequisite

1) Step 1

2) Step 2

3)

⇒ Intermediate result / additional information

⇒ Result

Steps and bullet points without mandatory sequence

•

•

-

-

Cross-references

See Technical Data [▶ on page 13]

Useful tips

TIP

Fuel

Use only the recommended fuel!

2.4 Version control

We update our manuals on a continual basis. The current version can be found at our homepage www.austroflamm.com.

2.5 Abbreviations

Abbreviation	Meaning
HMS	Heat Memory System
ST	Stoves

3 Safety

In this manual we give you numerous safety instructions for the safe operation of your stove. These instructions are characterized differently as follows, depending on their importance:

3.1 Importance of the safety instructions

NOTICE

Particular behaviour and/or activities that are required for safe working. Failure to follow this can result in material damage.

⚠ CAUTION

Possible dangerous situation (light or minor injuries and material damage).

⚠ WARNING

Possibly imminent danger to life and health of persons (severe injuries or death).

⚠ DANGER

Immediately imminent danger to life and health of persons (severe injuries or death).

3.2 Warning of sources of danger

3.2.1 General safety instructions

- The information in this manual represents generally applicable standards and rules. National and European standards, local and building regulations, together with fire regulations must also be complied with.
- Before operating your stove, carefully read through the entire manual and observe the instructions and warnings.
- Only approved transport aids with sufficient load-bearing capacity may be used to transport your stove.
- Caution - varnish is not an anti-rust protection!
- Burn only the fuel listed and approved in the section.
- It is strictly forbidden to burn or introduce highly flammable or explosive substances, such as empty aerosols and the like, into the firebox or to store them in the immediate vicinity of your stove due to the risk of explosion.
- No loose or easily flammable items of clothing should be worn when laying the fire.
- Please note that placing non-heat-resistant objects on, or near, the stove is forbidden.
- Do not place any items of laundry on the stove to dry. Laundry racks or the like must be placed at a sufficient distance from the stove. - (Fire hazard!)
- This stove is not a slow-burn fire.
- While your stove is in operation, it is forbidden to process highly flammable or explosive substances in the same room or in adjoining rooms.
- The stove must only be operated with the doors closed.
- The door and all the stove's control devices must be closed when the stove is not in operation.

- Please note that the surfaces of this stove heat up considerably during operation. We recommend that you use the protective glove supplied to operate your stove.



- Please alert children to these dangers, and keep them away from the stove when it is operating.

⚠ DANGER

Danger of overheating

To prevent damage you must **NEVER** operate your stove with a greater quantity of fuel than the quantity given in these instructions, either during its initial commissioning or every time you subsequently light it up again!

- Your stove is not suitable for use as a ladder or a stand.

3.2.2 Special types of danger and personal protective equipment

For certain activities such as installation/dismantling, particular care must be taken that the following safety equipment is worn:

	Safety gloves
	Safety shoes

4 Product overview

4.1 Intended use

The Austroflamm stove described in this manual is manufactured and tested with a type A1 self-closing and locking door under EN test EN 13240.

NOTICE

Operation is only permissible with closed/bolted door.

4.2 Identification of the product

In the following illustrations we give an overview of the most important dimensions and the nameplate positioning.

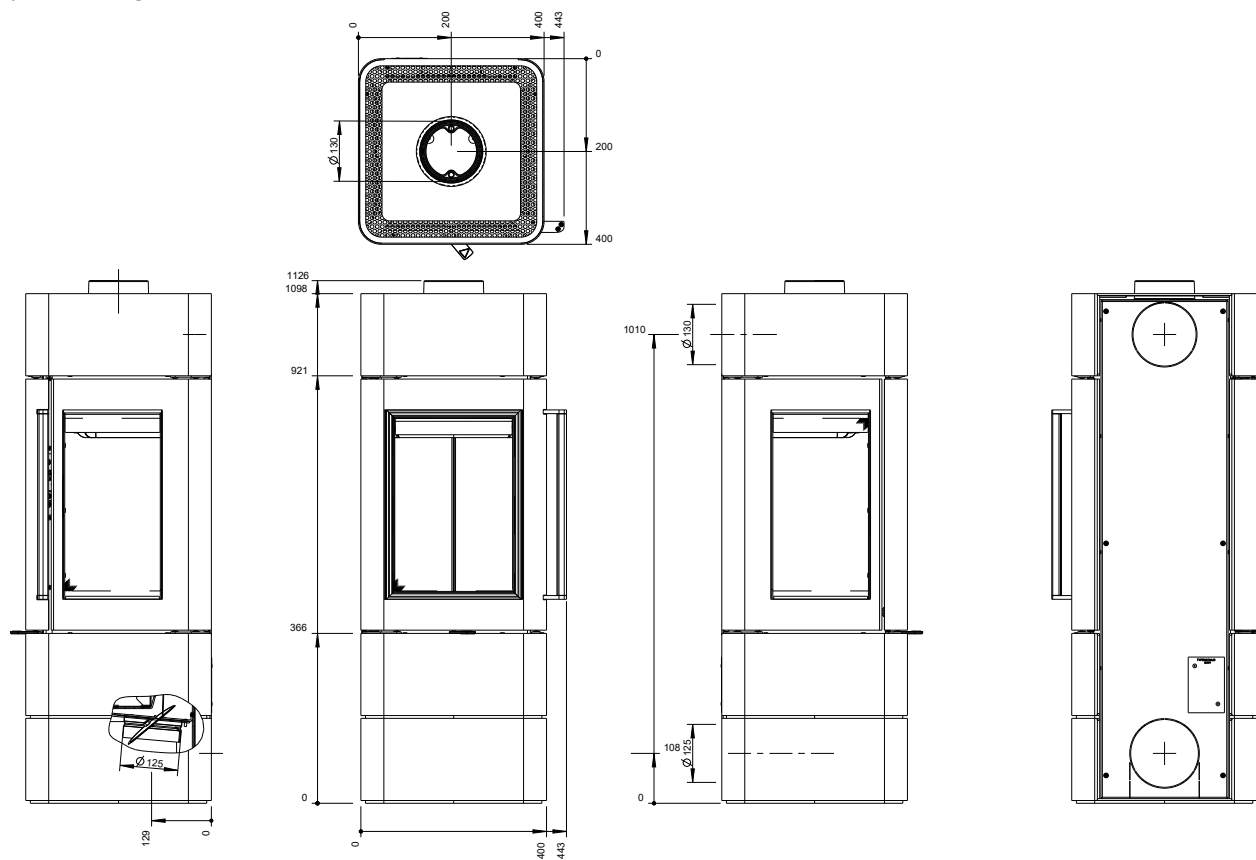

Fig. 1: Dimensions

- 1) Open (+) and closed (-) (primary/secondary air controller)

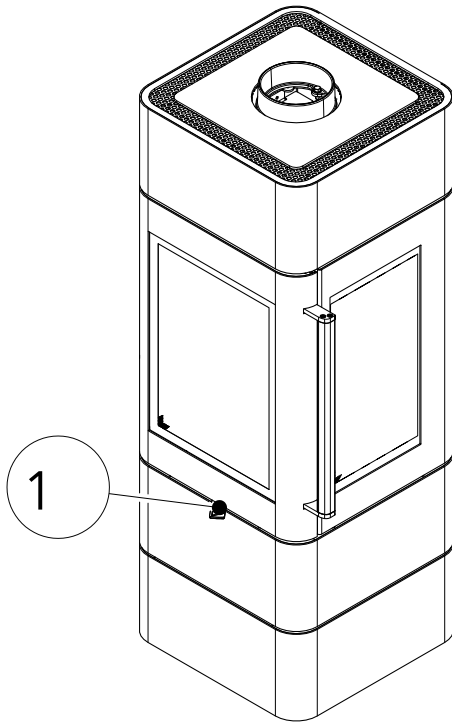

Fig. 2: Air control

Safety distances

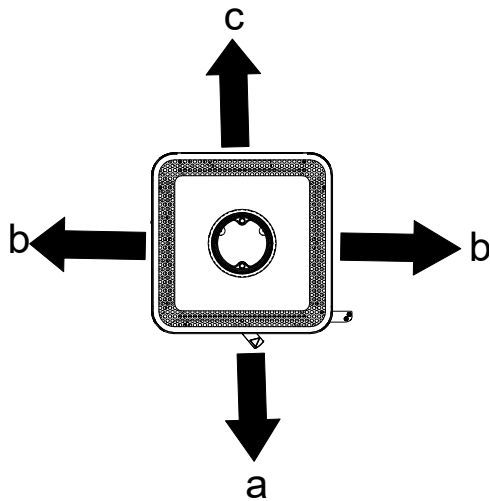

Fig. 3: Safety distances (view from above)

4.3 Energy label

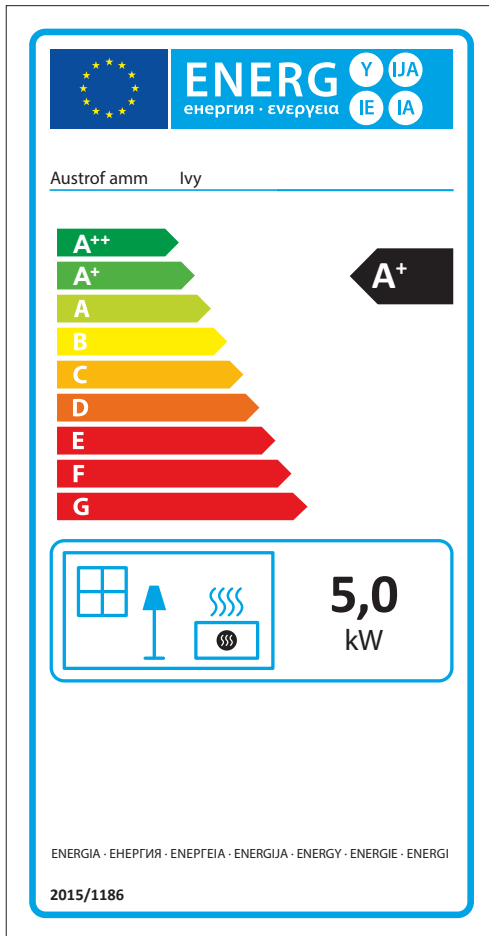

Fig. 4: Energy label

4.4 Positioning of the nameplates

Here we show where you can find the nameplate. You can find a copy of the nameplate of your stove on the back of this manual.

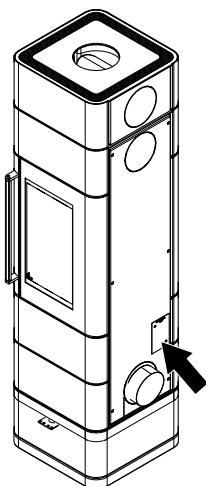

Fig. 5: Nameplate

The type label is located on the rear of the stove.

5 Technical data

As a type 1 stove, a connection to a chimney already occupied with other solid-fuel stoves and ovens is possible provided that the chimney rating under DIN 4705 – part 3, does not contravene this.

5.1 Technical data according to Regulation (EU) 2015/1185 and delegated Regulation (EU) 2015/1186

Contact details for the manufacturer or their authorized representative

Manufacturer:	Austroflamm GmbH
Contact:	-
Address:	Austroflamm-Platz 1
	4631 Krenglbach
	Austria

Appliance details

Model identification(s):	Ivy 2.0
Equivalent models:	-
Test reports:	RRF - 40 19 5327-1
Applied harmonized standards:	EN 13240
Other standards/technical specifications. Specifications:	-
Indirect heating function:	no
Direct heat output:	5.0 kW
Indirect heat output ¹ :	-

Properties for operation with the preferred fuel

Space heating annual use efficiency η_s :	72.0 %
Energy efficiency index (EEI):	108

Particular precautions for assembly, installation or maintenance

Described in the individual sections of the operating manual.

Fuel	Preferred fuel (only one) ² :	Other suitable fuel(s) ³ :	η_s [x%]:	Space heating emissions at nominal heat efficiency (*)				Space heating emissions at minimum heat efficiency ⁴ (*) (**)			
				PM	OGC	CO	NOx	PM	OGC	CO	NOx
				[x] mg/Nm ³ (13% O ₂) ⁵				[x] mg/Nm ³ (13% O ₂) ⁶			
Log, moisture content \leq 25 %	yes	no	72.0	20	40	1125	116	-	-	-	-
Compregnated laminated wood, Moisture content < 12 %	no	no	-	-	-	-	-	-	-	-	-
Other woody biomass	no	no	-	-	-	-	-	-	-	-	-
Non-woody biomass	no	no	-	-	-	-	-	-	-	-	-
Anthracite and dry steam coal	no	no	-	-	-	-	-	-	-	-	-
Coking coal	no	no	-	-	-	-	-	-	-	-	-
Semi-coke	no	no	-	-	-	-	-	-	-	-	-
Bituminous coal	no	no	-	-	-	-	-	-	-	-	-

Lignite briquettes	no	no	-	-	-	-	-	-	-	-	-
Peat briquettes	no	no	-	-	-	-	-	-	-	-	-
Briquettes made from a mixture of fossil fuels	no	no	-	-	-	-	-	-	-	-	-
Other fossil fuels	no	no	-	-	-	-	-	-	-	-	-
Briquettes made from a mixture of biomass and fossil fuels	no	no	-	-	-	-	-	-	-	-	-
Other mixture of biomass and solid fuels	no	no	-	-	-	-	-	-	-	-	-

(*) PM = dust, OGC = organic gaseous connections, CO = carbon monoxide, NO_x = nitrogen oxide

(**) Only required when using correction factors F(2) or F(3).

Properties for exclusive operation with the preferred fuels⁷

Specification	Symbol	Value	Unit	Specification	Symbol	Value	Unit
Heat output				Thermal efficiency (fuel efficiency) (based on the NCV)			
Nominal heat efficiency	P _{nom}	5.0	kW	thermal efficiency (fuel efficiency) at nominal heat efficiency	η _{th, nom}	82.0	%
Minimum heat output (standard value)	P _{min}	-	kW	thermal efficiency (fuel efficiency) at minimum heat output (standard value)	η _{th, min}	-	%
Auxiliary power consumption				Type of heat output/room temperature control			
At nominal heat efficiency	el _{max}	-	kW	single-level heat output, no room temperature control			yes
At minimum heat output	el _{min}	-	kW	two or more manually adjustable levels, no room temperature control			no
In standby condition	e _{SB}	-	kW	Room temperature control with mechanical thermostat			no
Pilot flame power requirement				with electronic room temperature control			
Pilot flame power requirement (if present)	P _{pilot}	-	kW	with electronic room temperature control and daytime regulation			no
				with electronic room temperature control and weekday regulation			
				Other regulation options (Multiple answers possible)			
				Room temperature control with presence detection			
				Room temperature control with open window detection			
				with remote control option			

¹ There is no entry for fireplaces without water-carrying components.

² Values for annual use efficiency and emissions must be given here for the preferred fuel.

³ Values for annual use efficiency and emissions must be given here for all other suitable fuels.

⁴ Corresponds to partial load heat output as per EN 16510

⁵ Specification in mg/m³ for heated filter method (in compliance with Annexe III, number 4, letter a, section i, point 1) or g/kg for measurement in dilution tunnel (in compliance with Annexe III, number 4, letter a, section i, point 2 and 3.)

⁶ Specification mg/m³ for heated filter method (in compliance with Annexe III, number 4, letter a, section i, point 1) or g/kg for measurement in dilution tunnel (in compliance with Annexe III, number 4, letter a, section i, point 2 and 3.)

⁷ Specifications are made here for the preferred fuel only.

5.2 General specifications

Technical data	Basic appliance
Height [mm]	1098
Width [mm]	443
Depth [mm]	400
Weight [kg] steel/ceramic/soapstone	125
Flue pipe outlet, diameter [mm]	130
Nominal heat efficiency [kW] as per EN test EN 13240	5
Heat output, minimum [kW]	2.5
Maximum heat output [kW]	7
Space heating capacity, at least (depending on the building insulation) [m ³]	48
Maximum room-heating capacity (depending on the building insulation) [m ³]	124
Minimum distance from non-flammable materials [mm]	50
Safety distances to combustible materials a [mm]	1000
Safety distances to combustible materials c [mm]	750
Safety distances to combustible materials c [mm]	200
Max. amount of fuel to be deposited [kg] (wood/briquettes)	1.5/1.3

5.3 Data for the chimney/flue dimensioning

Exhaust gas values for the multiple occupancy of the chimney (according to DIN 4705 Part 3) or rating of the chimney (according to DIN 4705 Part 2)	
Flue gas mass flow [g/s]	4.2
Flue gas temperature [°C]	263
Minimum feed pressure at nominal heat output [Pa] closed	12
at 0.8 times nominal heat output [Pa]	10

6 Transport, handling and storage

6.1 Transportation



Fig. 6: Crate

Immediately checked the goods delivered for completeness and damage in transit.

Before installing the stove, check that all movable parts are working. Any defects before the installation of the stove must be reported.

Transport is with a crate. The crate facilitates transport of the stove using a lifting truck or forklift.

Remove the crate and dispose of it appropriately.

6.2 Transport brackets

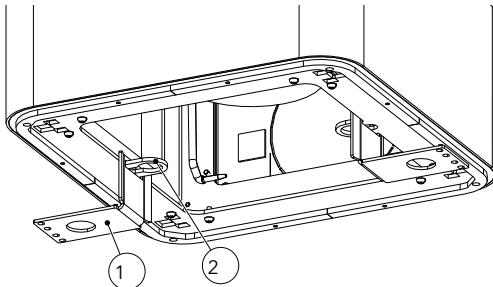

Fig. 7: Transport brackets

The transport brackets (1) are used to fasten the stove to the pallet during transport. These transport brackets must be removed before installing the stove.

The transport straps can be hooked into the eyelets to facilitate the lifting of the stove.

6.3 Storage

The stove must be stored in a dry room/warehouse. Protect against dirt, heat and moisture.

The following illustrations are attached to the crate and must be observed:



- Fragile - always place upright - protect against moisture and store dry.
- Remove and dispose of packing material in an environmentally friendly manner.
- The crate can be disposed of in the separate collection for packaging. Local disposal regulations must be observed.

7 Requirements at the installation location

7.1 Safety distances to be observed

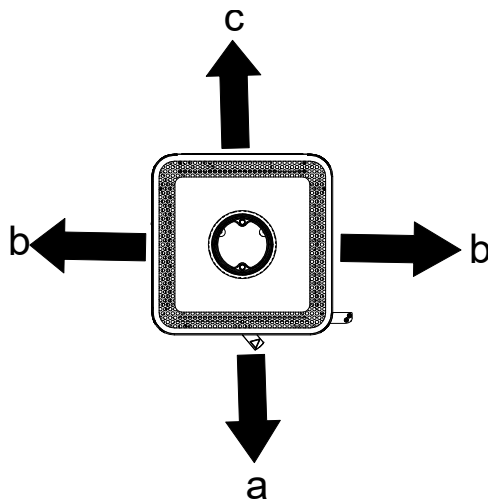

Safety distances to be observed from combustible materials (minimum distances - see also type plate).

- a) 1000 mm (at the front in the radiation area)
- b) 750 mm (at the sides in the radiation area)
- c) 200 mm (rear)

Fig. 8: Safety distances (view from above) up

7.2 Combustion air

An adequate supply of combustion air must be provided during operation. With a modern very thick building shell it can happen that the combustion air supply is not guaranteed for balanced flue operation or that the draft behavior is impaired. In this case an adequate supply of combustion air must be provided. Your Austroflamm specialist dealer will be happy to advise you.

TIP

Ensure that combustion air openings are not closed!

7.3 Chimney requirements

When connecting the flue pipes to the chimney, national and/or local safety regulations must be complied with. Your Austroflamm stove is fitted at the factory with a flue outlet at the top (diameter 130 mm). The connection can, as described in these instructions, be rearranged to the bottom. When connecting with other pipe diameters the approval of your responsible chimney sweep is required. The flue pipe connection and flue pipe transitions must be sealed accordingly. Your Austroflamm specialist dealer knows the guidelines and will be happy to advise you. For your own safety the connection of the flue pipe must be carried out by a technically competent person.

7.4 Floor load-bearing capacity

Before installing, verify whether the load-bearing capacity of the substructure can withstand the weight of your Austroflamm stove.

7.5 Floor condition

In the radiation area of the pane (in front of the stove), the floor must not be combustible.

7.6 Room of installation

Note that the room in which the stove is installed must have at least one door / one window leading to the outside, or be directly connected to such a room. For balanced flue operation, other heating appliances and extractor hoods must not be operated together with this heating appliance as part of the room air system.

8 Fuel material/-quantity

8.1 Fuel

Wood

Many of our native types of wood can, after being appropriately dried, be burnt CO₂-neutral in heat-producing appliances. Wood stands out because it grows again, can be sustainably harvested, requires little or no extra external energy to be invested in the fuel, and has a short journey from the producer to the consumer, which provides an optimal climate balance.

The most common types of wood to use in the stove are beech, yoke elm, birch, larch, spruce and pine. The most important criterion for burning in a heat-producing appliance is that the fuel has been sufficiently dried through. For this purpose the prepared pieces of log should be stored for at least two years. The legislator stipulates a maximum water content of 20%. That is still however a lot of water sitting in the capillaries of the wood. A piece of firewood only becomes good when its water content comes to a maximum of 12 to 13%. The differences in combustion behaviour are striking and clearly detectable even by the layman.

Types of wood other than the ones referred to above are also suitable for burning. However each heat-producing appliance should be checked for how their use affects combustion behaviour. Oak for example burns with a rather shorter flame and more embers. Oakwood catches fire with greater difficulty, and due to hardness of the wood it is not split as well (small) as other types of wood, which again has a negative effect on combustion behaviour. It is however a good energy source, and, correctly processed, also suitable as firewood.

Softwoods (fir, pine, spruce) should if possible be mixed with hardwood. Softwoods have a higher proportion of tannin, which leads to more deposits in the heat-producing appliance, the connecting pipes and the chimney. If only softwood is burnt, this can lead more quickly to a build-up of shining soot. Mixing with hardwood (for example, beechwood) reduces this effect.

The size of your heat-producing appliance's combustion chamber will dictate whether your firewood is 25cm, 33cm or 50cm in length. 50cm pieces of log should preferably dry for somewhat longer (laid down for three years or more), because wood is dried out mainly by the leakage of water from the capillaries - and that simply takes time. And the path from inside to outside in a 50cm-long piece of log is twice as long as in a 25cm-long piece of log. The important thing is that the wood is well split. This means that the circumference of a piece of log (once all sides are measured around the cutting point) must be a maximum of 15-25cm. Pieces of wood cut to this size dry more easily - above all, however, they give the fire (the temperature) a greater attack area and thus make it easier to evolve gas and thus to burn. Also the quantity of fuel can be better measured out. Thanks to their outstanding levels of efficiency, modern heat-producing appliances require just a fraction of the amount of wood of earlier stoves. Here smaller pieces of log can be placed according to the manufacturer's specifications - large pieces of log often exceed the maximum specified quantity with just a single piece.

Not everyone has a hygrometer at home for determining the water content in wood, particularly when good reliable units cost several hundred euros. However you can make a good estimate of how suitable your fuel is by carefully observing combustion behaviour. A "good" wood fire will only smoke briefly in the ignition phase, hardly at all after that. It will burn with a light (yellow to orange-coloured) long flame. Little residue will occur in the combustion chamber, most of it disappearing again when the fire is fully developed. Another good criterion for assessing whether a piece of log is suitable for combustion is its weight. Most manufacturers also specify the amount to be laid in kg/weight. Example: a piece of beechwood 33cm in length with a circumference of approx. 20cm weighs approx. 1kg when it is suitable (dry enough) for burning. Therefore 25cm in length gives approx. 750 grammes, and 50 cm in length approx. 1.5kg.

Please observe at all times the maximum specified amount to be laid, even when putting on more wood! Otherwise your fire will not provide the desired efficiency - but above all considerable damage may be caused to your appliance, to gaskets and material and to the flue gas duct.

The wood may only be burnt untreated. NEVER burn treated woods, not even wood processed with natural substances or organic glazes. Wood waste does not belong in the stove!

Wood briquettes

Many people like wood briquettes as a fuel because they require less storage space than wood, can be stocked or sold in small quantities and - at least at first glance - make less work than wood. Within the scope of production, the quality of briquettes is consistent. Wood briquettes do not need to be stored for a long time to be dried out. Due to the raw material (unrefined chips) and the production process they have an already defined residual moisture.

If wood briquettes are designated as a suitable fuel, then this still only applies to this fuel, NOT for coal-, paper-, bark- or other pressed items, such as pellets.

In spite of various standardizations and many advertising promises, there are also considerable differences in quality in wood briquettes. But even with good fuel quality, combustion behaviour is different from that of unrefined log. And not every wood briquette burns equally well in every stove. Before you decide on a particular variety and perhaps even store this up in larger quantities, you should extensively test the wood briquettes under various draft conditions. Most suppliers keep "test packages" for this purpose that can be purchased at preferential prices to test out and compare with one another the various types offered.

TIP

When burning wood briquettes, the maximum quantity specified in these instructions must also be observed. The quantity must not be exceeded.

As the wood is pressed and thus has little spatial volume for the same weight, modern heat-producing appliances with a low placement quantity often have "little fire heaps" occur, leading one to wonder whether a fire can burn at all with so little fuel. Nevertheless you must never exceed the maximum placement, because that would cause damage. Many wood briquettes change during the temperature increase when burning, by "opening up". This should not worry you as it is normal. When inserting wood briquettes make sure that this expansion as far as possible does not press not in the direction of the window, as otherwise this will get very dirty.

In principle you should not insert wood briquettes as one piece, but rather break them at the layer thicknesses, which are usually visible in slices, and place smaller pieces in the combustion chamber, not in an interlocking manner, but randomly. This way you will ensure that the combustion air reaches more burning material and flows around it better. Wood briquettes require a stronger air current, an expert eye and perhaps a bit more patience, until you get the knack of it. Since less volume is available (although the same mass, it takes less space up), the fire is generally smaller and does not burn so high and vivaciously as when burning log. When wood briquettes alone are burnt, this therefore generally leads to haziness in the combustion chamber, as well as on the stove window. Not all areas of the combustion chamber have the same temperature applied to them as when unrefined wood is burnt, which is why these deposits occur. It may be that with one variety of wood briquettes more deposits occur, whereas with another variety none at all. This suggests trying out various varieties to determine the suitable fuel for your heat-producing appliance. If you would really like to use wood briquettes, but don't get on quite well with them, then it may also help to mix the fuel. That means: Burn wood briquettes and unrefined log in the mixture ratio that achieves a good burning result for your heat-producing appliance.

Wood briquettes must also be stored dry. In general it can be said that pressed items with a hole in the middle usually burn better. Soft wood briquettes are to be preferred and are often more suitable than hard wood briquettes.

Approved fuel

Dry, well-stored, unrefined log (preferably hardwood) and/or wood briquettes.

Round wood must be split at least once so that it lights better. The diameter of the split piece of wood must not exceed 7 cm.

Explosive substances

It is strictly forbidden to burn or introduce highly flammable or explosive substances (empty aerosols and the like) into the firebox or to store them in the immediate vicinity of your stove. Risk of explosion!

Fuel

Only burn the recommended fuel.

Clean combustion

The firewood must be dry (rel. wood moisture < 15 %) and untreated. Furthermore the correct quantity of firewood must be burnt in order to achieve a clean, low-emission combustion.

8.2 Fuel quantity

Maximum fuel quantity

Your Austroflamm stove is designed for maximum efficiency: see Technical Data section. Too great a quantity of fuel can lead to overheating and damage to your Austroflamm stove!

Maximum amount of fuel to be deposited: 1.5 kg wood or 1.3 kg briquettes.

NOTICE**Overheating**

Too great a quantity of fuel can lead to overheating and damage to your Austroflamm stove

NOTICE

To avoid damage you must **NEVER** operate your Stove a greater quantity of fuel than that specified in this manual!

9 Installation

Installation must only be carried out by an authorized specialist company.

Before installing the stove, check that all movable parts are working. Any defects must be reported before the installation.

In the following sections we will give you information on

- the integration or attachment of appliance parts
- the rearrangement of the flue pipe connection
- The connection of the combustion air supply, and on
- other important facts relating to the installation.

9.1 Risks and dangers

Protective equipment

The following protective equipment must be used:

Type of protective equipment	
	Safety gloves
	Safety shoes

9.2 Execution

9.2.1 Rearranging the flue pipe connection

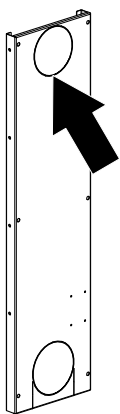
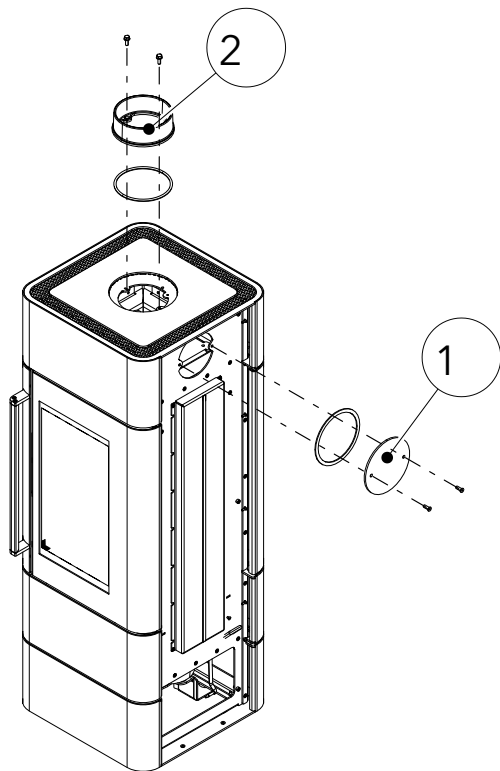

Fig. 9: Removing the perforated cut-out

- 1) First dismantle the rear panel. Proceed as described in the section Removing the rear panel [▶ on page 45].
- 2) Use a saw to remove the perforated cut-out on the rear panel.



- 3) Remove cover with seal (1) on the back.
- 4) Remove bracket with seal (2).

Fig. 10: Remove cover and bracket

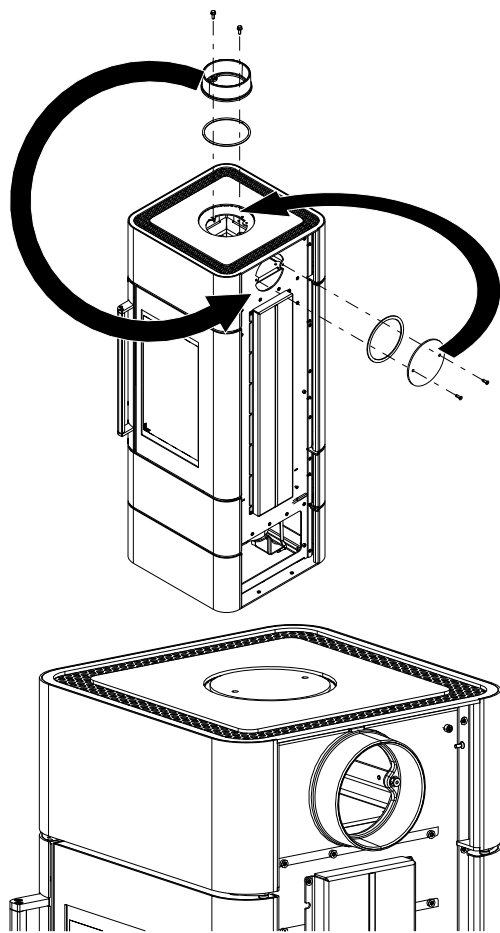

- 5) Replace parts and reinstall.

Fig. 11: Replacing cover and bracket

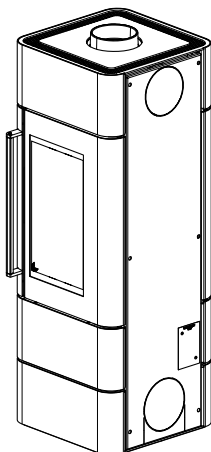

Fig. 12: Installing the radiation protection and rear panel

- 6) Reinstall the radiation protection and rear panel.

9.2.2 Installing the HMS

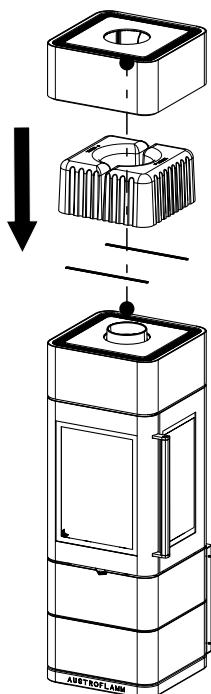

Fig. 13: Installing the HMS

- 1) Mount the HMS on the stove as depicted above and place the top box over the HMS bricks on top of it.

9.2.3 Mounting the Keramott

Numbering = installation sequence

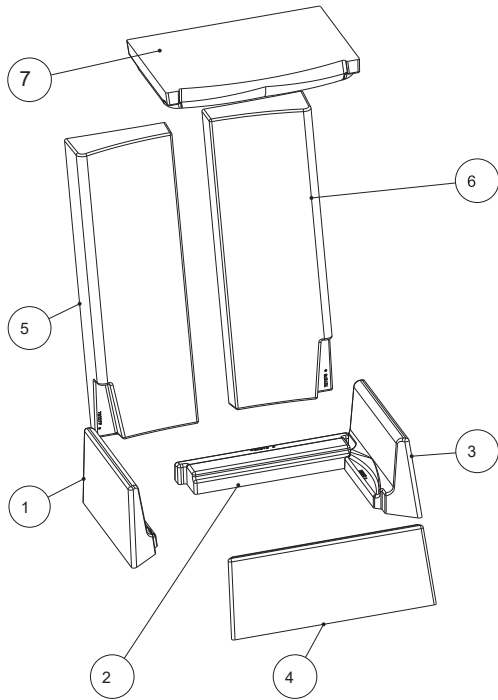

Fig. 14: Keramott

9.2.4 Mounting the base

- 1) First remove the stove from the wooden base.



Fig. 15: Remove the wooden base.

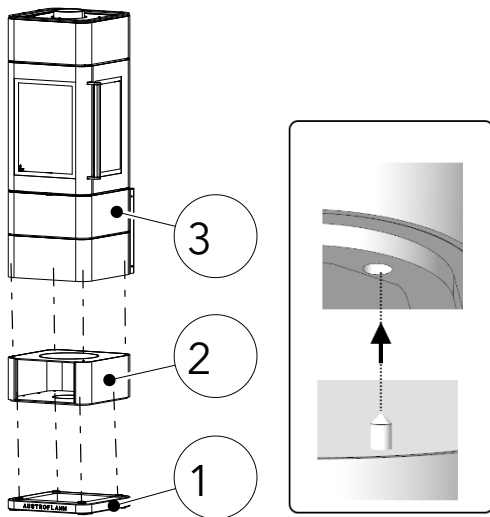

Fig. 16: Mounting the base.

- 2) Then mount the additional base (2) on top of the wooden base.
- 3) Insert the stove (3) into the base (2).

9.2.5 Mounting the side box

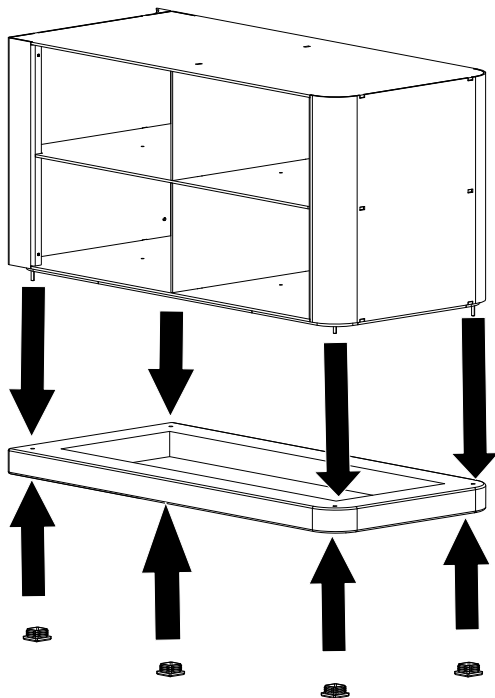

Fig. 17: Mounting the side box

- 1) Insert the side box on the wooden base.

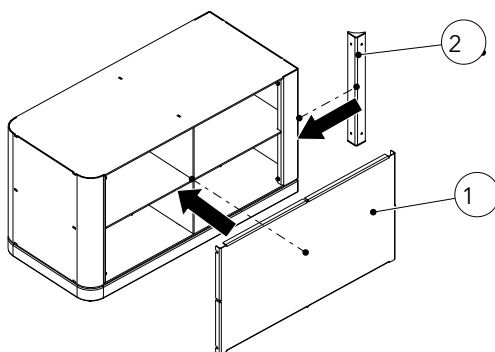

Fig. 18: Mounting the rear panel and elbow piece

- 2) Mount the rear panel (1) and the elbow piece (2).

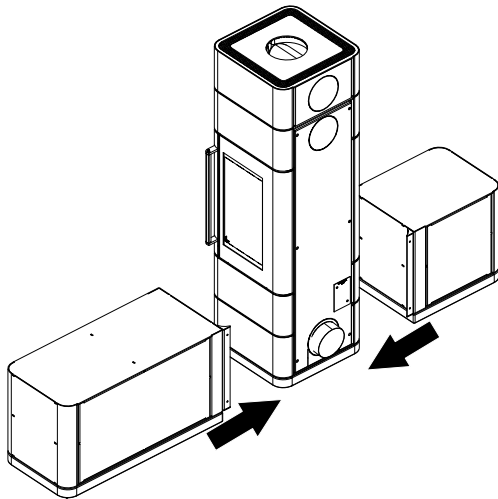

Fig. 19: Fastening the side box

- 3) Fasten the side box to the left and right of the stove.

9.2.6 Installing the log drawer

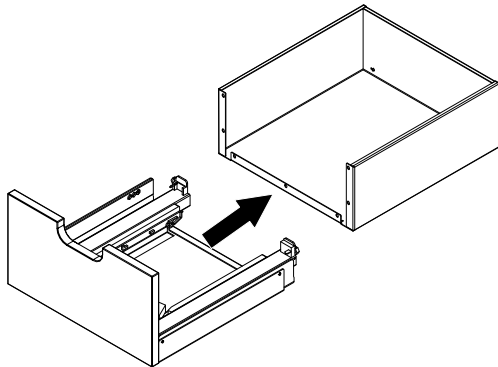

Fig. 20: Sliding the log drawer from the rail

- 1) Slide the log drawer from the rail.

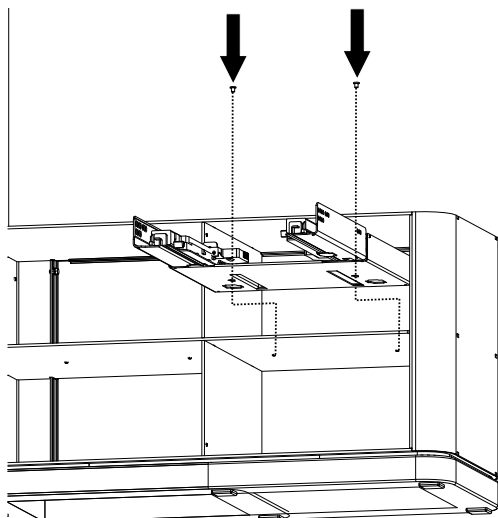

Fig. 21: Mounting the rail frame.

- 2) Mount the rail frame.

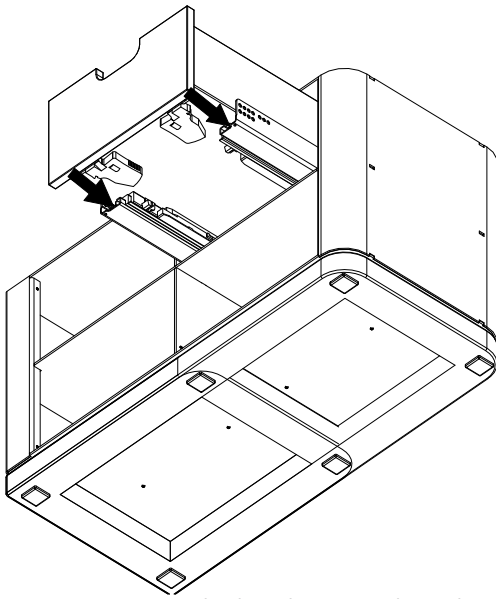

Fig. 22: Inserting the log drawer in the rail

3) Insert the log drawer in the rail.

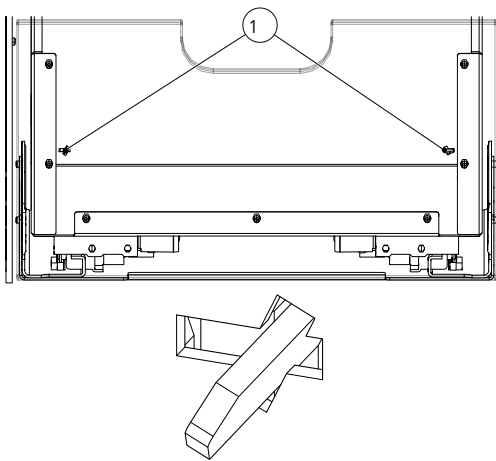

Fig. 23: Attachment pins

4) Attachment pins (1) must penetrate through the drawer.

9.2.7 Mounting the external air connection at the rear

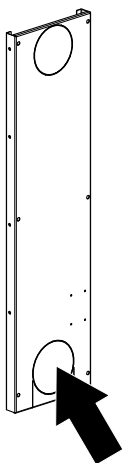

Fig. 24: Removing the perforated cut-out

- 1) First dismantle the rear panel. Proceed as described in the section Removing the rear panel [▶ on page 45].
- 2) Use a saw to remove the perforated cut-out on the rear panel.

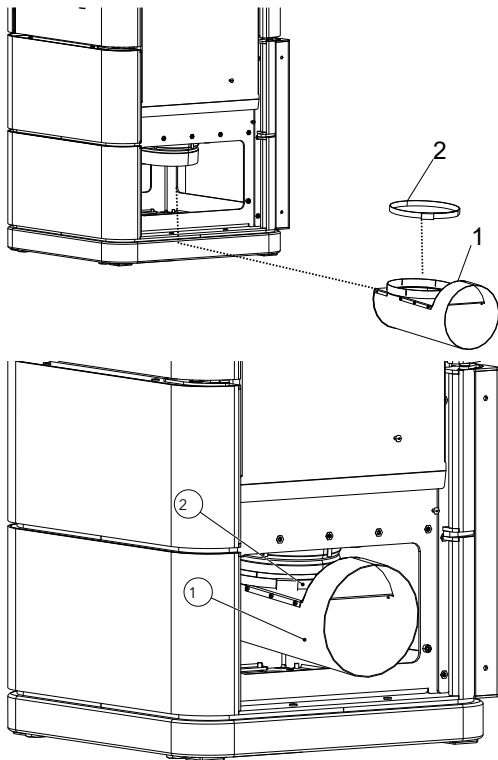

Fig. 25: Mounting the air supply adapter.

- 3) First attach the clamp (2) on the air supply adapter (1).
- 4) Mount the air supply adapter (1) from the rear and fasten it with the clamp.

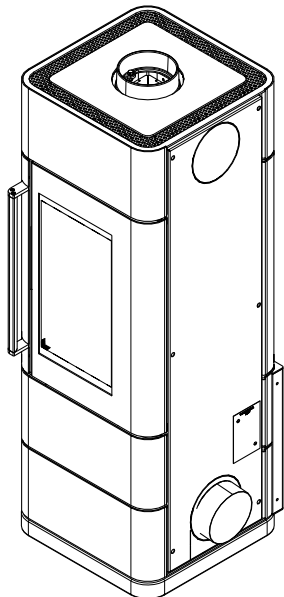

Fig. 26: Installing the rear panel

- 5) Reinstall the rear panel.

10 Settings

10.1 Adjusting the door

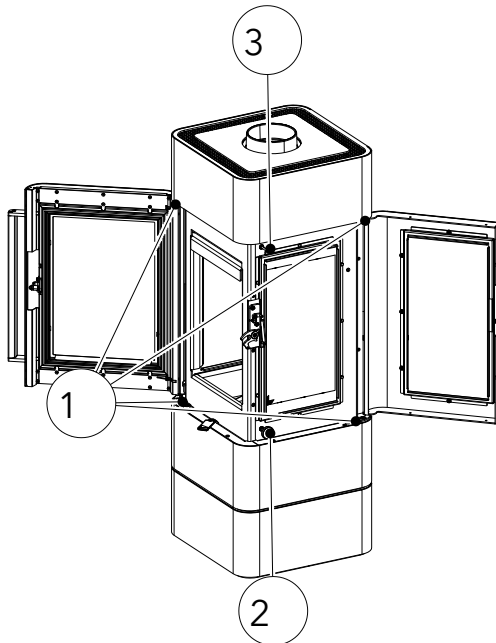

Fig. 27: Adjusting the door

- 1) Open the doors and set the doors at the marked points 1, 2 and 3 as follows.

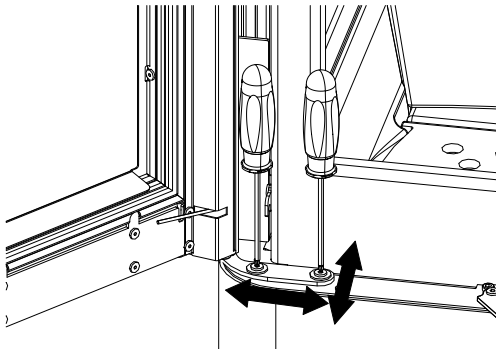

Fig. 28: Pos. 1 Adjusting the door

- You can adjust the doors by turning these screws - forward, back, left and right - with a screwdriver.

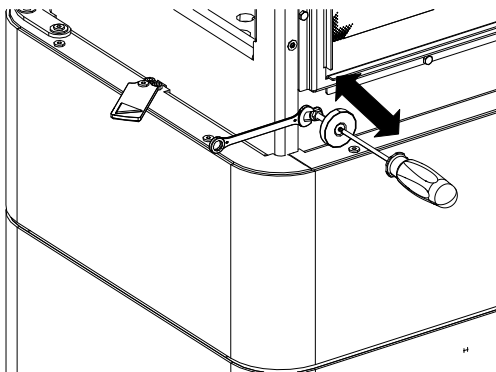

Fig. 29: Pos. 2 Adjusting the door

- Hold the screw nut with a screwdriver and adjust the magnet with a screwdriver (turn in or out).

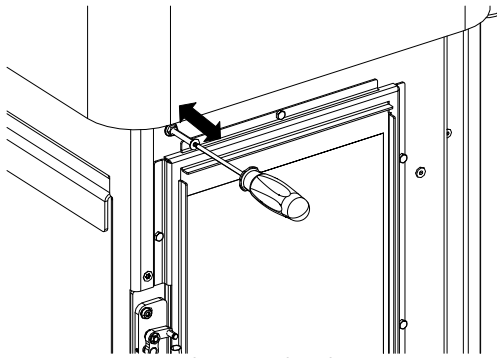

Fig. 30: Pos. 3 Adjusting the door

- Adjust the screw with a screwdriver (turn in or out).

10.2 Adjusting the door spring

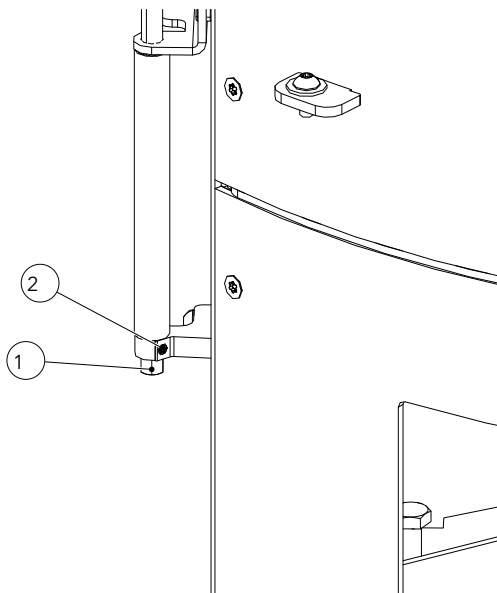

Fig. 31: Adjusting the closing pressure of the door

- 1) To adjust the door spring, the hob must be removed and only the left side cladding detached. Proceed as described in the section Removing the side cladding [▶ on page 46].
 - 2) At the bottom of the door there is a bolt which can be used to adjust the door closing pressure. Use an open-end wrench to secure the bolt at the lower end (1).
 - 3) Using a screwdriver, the closing pressure can be adjusted with the screw (2).
 - 4) Reattach left side cladding and the hob.
- ⇒ Closing pressure is adjusted

11 Commissioning

11.1 Initial Commissioning

NOTICE

During the initial commissioning and in the following 2-3 combustion cycles, only approx. 2/3 of the maximum fuel quantity is to be used.

NOTICE

To avoid damage you must **NEVER** operate your Stove a greater quantity of fuel than that specified in this manual!

During the first 3-4 combustion cycles at nominal heat output, odors may develop. The odors are caused by the evaporation of sheet metal greases and binding agents from the varnishing. Although unpleasant, these fumes are completely non-toxic. We therefore recommend that you well ventilate the room for the first few fires.

- 1) Remove all enclosed documents and appliance parts from the fireplace.
- 2) Read the operating manual through carefully before the initial commissioning.
 - ⇒ For optimally lighting we refer you to the section Making fire correctly.

Removing the ash box cover

Before the stove is operated for the first time, it is absolutely vital to remove the cover of the ash box from the stove.

Proceed as follows: (for a better understanding, see also steps 1 and 2 in the section Emptying the ash box)

- 1) Open door.
- 2) Raise the grate with the hook supplied with the stove.
- 3) Take off the cover and lift it up.
 - ⇒ Cover is inserted incorrectly when delivered.
 - ⇒ You need the cover when you empty the ash box.
 - ⇒ To empty the ash box we refer you to the section Emptying the ash box.

11.2 Balanced Flue Operation

The stove is generally approved as a balanced flue stove by the German Institute for Building Technology. If the combustion air is supplied directly to the fireplace from outdoors by means of a sealed pipe with a shut-off device, the stove may also be operated in utilization units with mechanical ventilation or ventilators.

If, however, the stove is used in this way, multiple occupancy of a chimney is not permitted.

The DIBT test applies to Germany

12 Operation

12.1 Before heating up

The stove can only function properly if there is sufficient combustion air coming to the room of installation (the appliance), specially if several firing installations are being operated at the same time. Ensure sufficient air supply before heating up. Open the combustion air flap on the stove and keep it open for the entire combustion period.

Devices for the supply of combustion air must not be modified.

12.2 Making fire correctly

To ensure the stove operates correctly and safely, it is important that the chimney generates the required draft. This must be checked in particular for each initial commissioning (e.g. after summertime) and in the transitional periods (e.g. when the wind is strong). If there is insufficient required draft, then paper or softwood chips can first be burnt in order to bring stove and chimney flue to temperature.

The air inlet of the stove must not be closed.

- 1) Clean grate.
- 2) If necessary empty ash box (beware of embers).
- 3) Fully open the primary/secondary air control.
 - ⇒ 1 = open
 - ⇒ 2 = closed

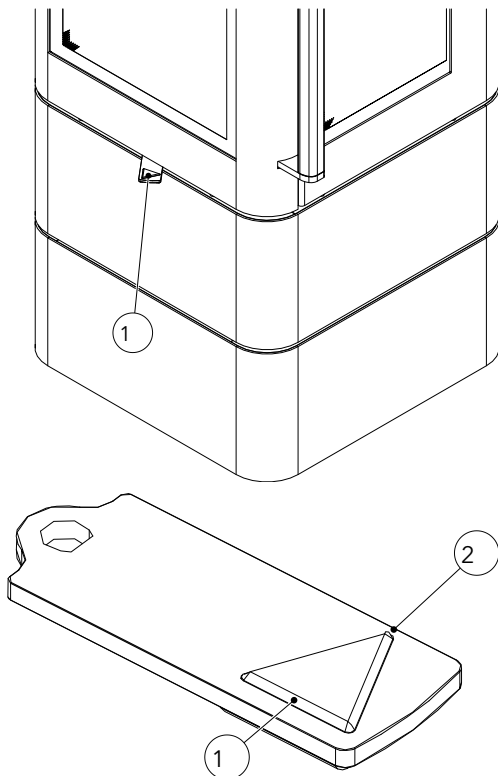

Fig. 32: Primary/secondary air controller

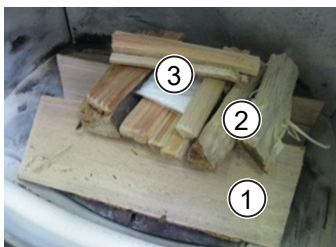

Fig. 33: Before kindling

- 4) Lay 2-3 pieces of log (1) (beech, oak, birch) across the bottom of the firebox.
- 5) Finely split softwood above it (2).
- 6) Place a firelighter (3) in the middle and light it.
 - ⇒ Never use petrol, spirit or similar for ignition!

1	Log
2	Softwood
3	Firelighter

- 7) Close the door.
 - ⇒ It is best to allow the first layer of wood to combust without altering the air damper setting.
 - ⇒ If only the bed of embers is left (no more flames), you can place another layer of log.
- 8) When stoking up, proceed as for heating up:
 - ⇒ Open combustion air supply.
 - ⇒ Carefully open stove door.
 - ⇒ Put wood on.
 - ⇒ Close door.
- 9) As soon as the pieces of firewood are burning well all around (light, high flames), you can control the air supply with the controller.
 - ⇒ Control at maximum setting right = maximum heat output
 - ⇒ the flames should always burn yellow and never blue or with black flame tips (otherwise feed more air in).
 - blue = too much air
 - black = too little air
 - ⇒ During combustion do not totally close the air supply (danger of deflagration!).



Fig. 34: Flame pattern

12.3 Heating in the transition period

In the transition period, i.e. during high external temperatures, a sudden temperature rise can disrupt the chimney draft so that the fuel gases are not completely drawn off. In this case the appliance must be filled with smaller quantities of fuel and operated with the air damper/-controller on a higher setting so that the available fuel combusts more quickly (with a flame developing) and the chimney draft stabilized as a result.

TIP

To prevent resistance in the firebed, the ashes should be removed more frequently.

13 Maintenance

13.1 Changing the seal on the door

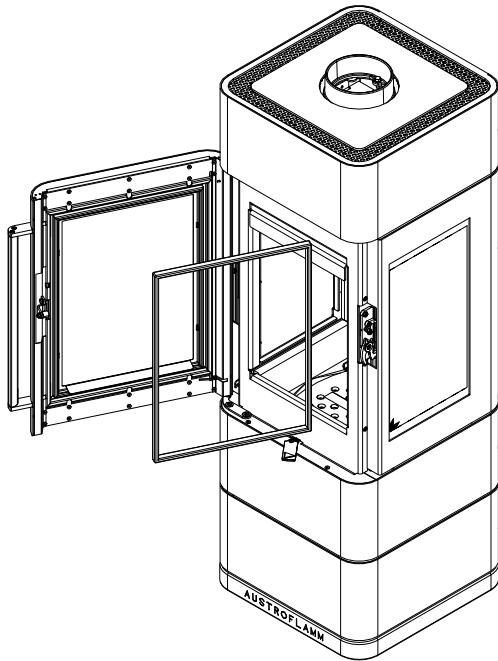

- 1) Remove old seal from the door.
 - 2) Glue in new seal with a suitable adhesive (e.g. silicon B310).
- ⇒ Repeat these steps for the other door as well.

Fig. 35: Changing the seal

14 Cleaning

14.1 Cleaning the stove, flue gas ducts and flue pipe

The stove, the flue gas ducts and flues should be annually - possible even more often, e.g.

- after the chimney has been cleaned
- checked for deposits
- cleaned as necessary.

TIP

The chimney must likewise be regularly cleaned by the chimney sweeper. Your master chimney sweep will inform you of the necessary intervals. The stove should be inspected annually by a specialist

14.2 Emptying the ash box

- On a regular basis and in good time (at least 1 x per week) remove the ashes from the firebox and empty the ash box.
 - If the firebox is not regularly cleaned of ash then there is a danger that the combustion air openings become blocked and the appliance suffers damage.

To empty the ash box, proceed as follows:

NOTICE

Be aware when emptying the ash box that there might be embers in the ash box. Only remove the ash box when the stove is in the cold state.

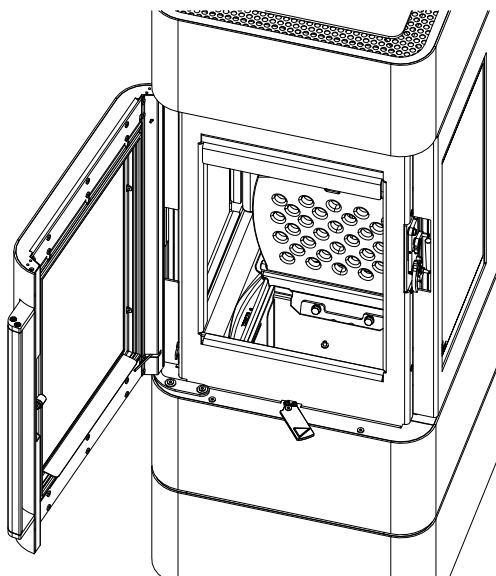

Fig. 36: Raising the grate

- 1) Open door.
- 2) Raise the grate with the attached hook.

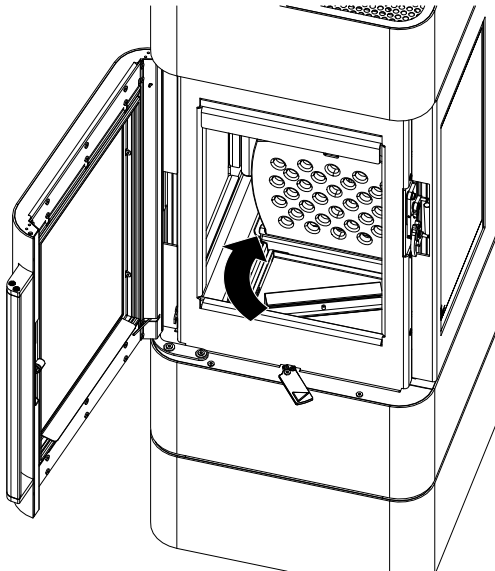

Fig. 37: Putting the cover on the ash box

- 3) Take the supplied cover and use it to cover the ash box.
- 4) Turn the handle of the cover clockwise until the handle engages.

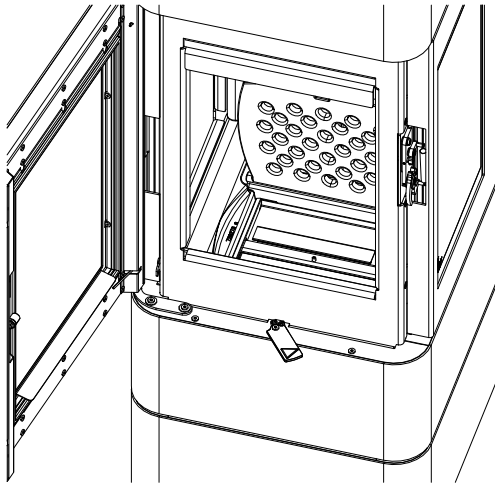

Fig. 38: Closing the cover

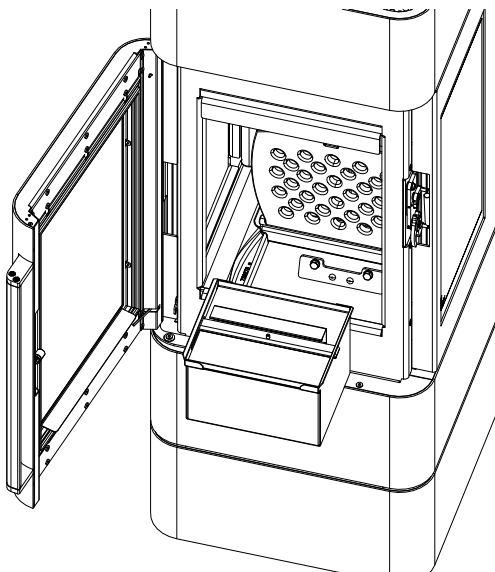

Fig. 39: Removing and emptying the ash box

- 5) Remove the ash box from the stove and empty it.
- 6) Reinsert the ash box after emptying it.
- 7) Close the grate again.

14.3 Cleaning the door window

Spray window with glass cleaner and leave it for a moment to take effect.

- We recommend cleaning the glass with our Austroflamm glass cleaner or a commercially available window cleaner.
- Prevent door- or window seals from coming into contact with water or cleaner, since these will otherwise harden and in doing so lose their function. Only intact seals ensure that your stove functions flawlessly.

14.4 Cleaning surfaces

- Varnished surfaces may only be cleaned with a soft cloth (if necessary damp).
- Soak up dissolved dirt with absorbent cloths or household paper.
- For stainless steel surfaces there are also special cleaners.

15 Help

Problem	Cause	Solution
The glass window is sooty	Insufficient draft	from time to time (depending on use) the window must be cleaned with glass cleaner Clarification with chimney sweeper (poss extend chimney/measure draft)
	incorrect operation of the air control	It is imperative that the air controller is operated in accordance with the instructions (if secondary air is closed too far, the glass pane will become sooty very quickly)
	excessively large pieces of firewood firewood too damp	Comply with quantity and size according to the instructions
	Operating temperature has not been reached	Use more fuel, dry wood (< 15 % residual moisture), pay attention to air regulation
The chimney is too small	The chimney draft is insufficient	Ask your chimney sweep to carry out a draft measurement
	Exhaust ducts and combustion chamber sooted up	Use more fuel, dry wood (< 15 % residual moisture), pay attention to air regulation
The stove emits a strong odor and smokes externally	Stove-enameling phase of the varnish	During the first heating cycles, the varnish hardens and smells in the process
	The stove surface is dusty/soiled	Keep the surfaces of the stove clean Keep the floor area clean around the stove
Flue gas escapes when stoking up and during the heating phase	Chimney draft too low, flue pipe connection leaky	Check connection points and if necessary reseal Check chimney draft
	Door opened before combusted down to embers	Only stoke up when only embers are present (no more visible flames)
The fire is too weak and/or goes out	Air control closed (-)	Air control open (+)
	Wood too damp	Are you using dry wood (< 15 % residual moisture)?
	External temperature too high (>15 °C)	
The room is not warm enough	Convection air grille closed	Open convection air grille
	Chimney draft too high	Clarification with chimney sweeper (poss shorten chimney/measure draft)
The fire burns down too quickly and uncontrollably	Air control open (+)	Throttle combustion air supply after the operating temperature has been reached in the firebox (+ / -)
	Seals worn	Check whether the seals on the inside of the door are continuous and in working order, if necessary replace
	Firebox door not closed properly	Close firebox door
	Chimney draft too high	Clarification with chimney sweeper (poss shorten chimney/measure draft)
Ceramic windows become sooty very quickly	Unsuitable wood used	Use dry unrefined wood. See information about this in the Fuel section

Problem	Cause	Solution
	Operating temperature not reached	Bring stove to the operating temperature
		Sooting up of the window after 8- 10 hours of fires is normal
	Chimney draft too low	Contact chimney sweep

15.1 Firebox lining

The lining of your stove consists of Keramott, a high-quality material with special combustion properties and an attractive appearance. During or after operation this lining may have superficial hairline cracks, which do not however affect functioning. Replacement of such parts is not required!

15.2 What to do in the event of a chimney fire

If fuel used is incorrect or too moist, then due to deposits in the chimney this may lead to a chimney fire.

- 1) Call the fire department and the district master chimney sweep!
- 2) Close the combustion air.
- 3) Enable access to the cleaning openings (e.g. basement and attic).
- 4) Remove all flammable material from the chimney.
- 5) Inform your district master chimney sweeper before recommissioning of your stove and have your chimney checked for any damage.

15.3 What to do in the event of faults

Should faults occur, your dealer will require the following details:

- Serial number and appliance model as per the nameplate
- Original invoice (date of sale)

16 Accessories

Have defective parts (accessories, spare parts) replaced by your specialist stove dealer. This guarantees that stove is and remains safe and functional.

17 Spare parts

Accessories

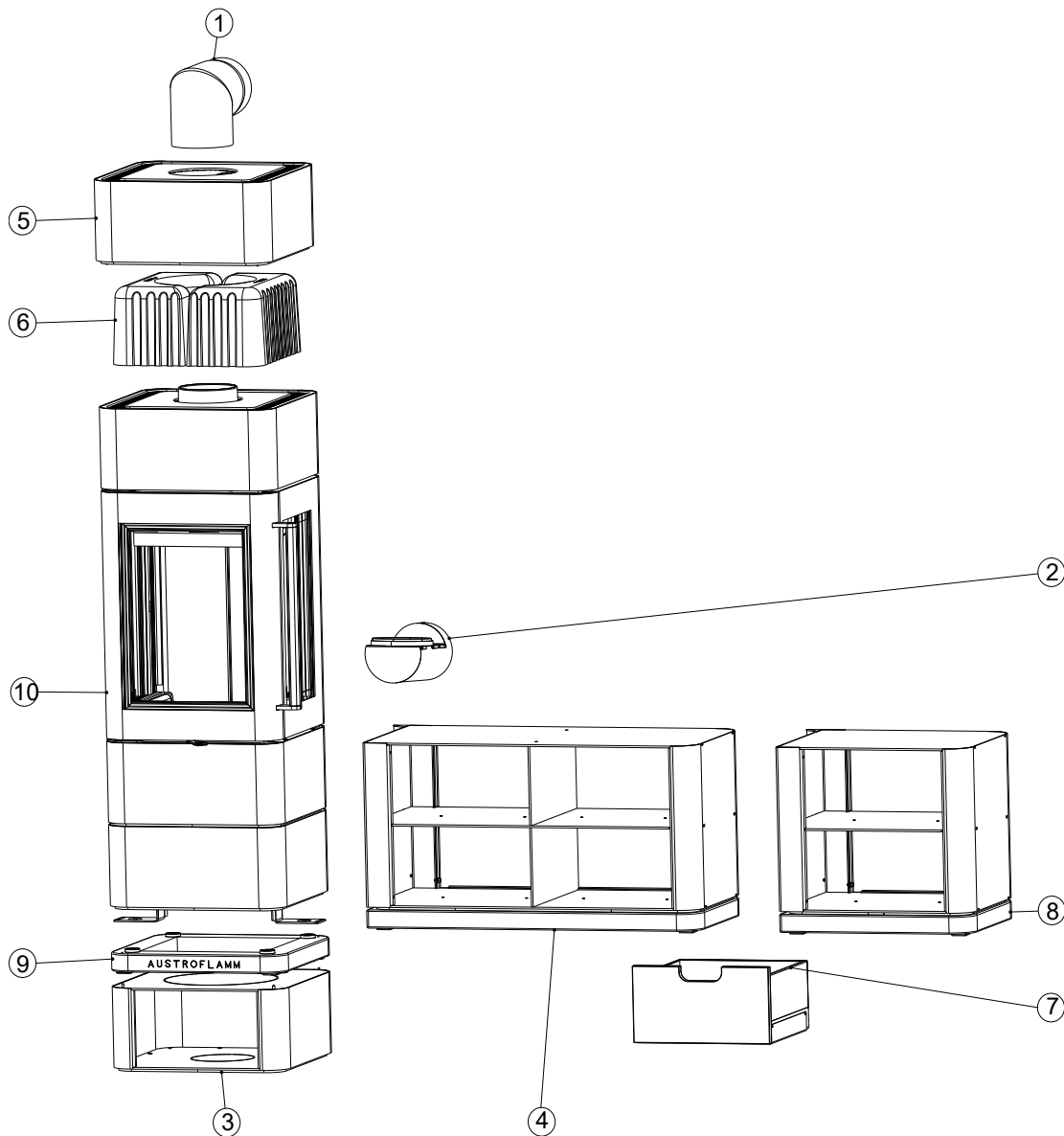

Pos. No.	Quantity	Item	Article No.
1	1	Elbow piece 130 Dexter	-
2	1	Air supply adapter AH complete	074002-29
3	1	Base	078002-29
4	1	Side box right/left (Conversion option for installation left)	078003-29
5	1	Top box	078004-29
6	1	HMS complete (only with top box Pos. 5)	078005
7	1	Log drawer (LD) complete (only with side box Pos. 4 and 8)	078006
8	1	Small side box right/left (Conversion option for installation left)	078007-29
9	1	Base complete	078008
10	1	IVY 2.0	078101

Keramott

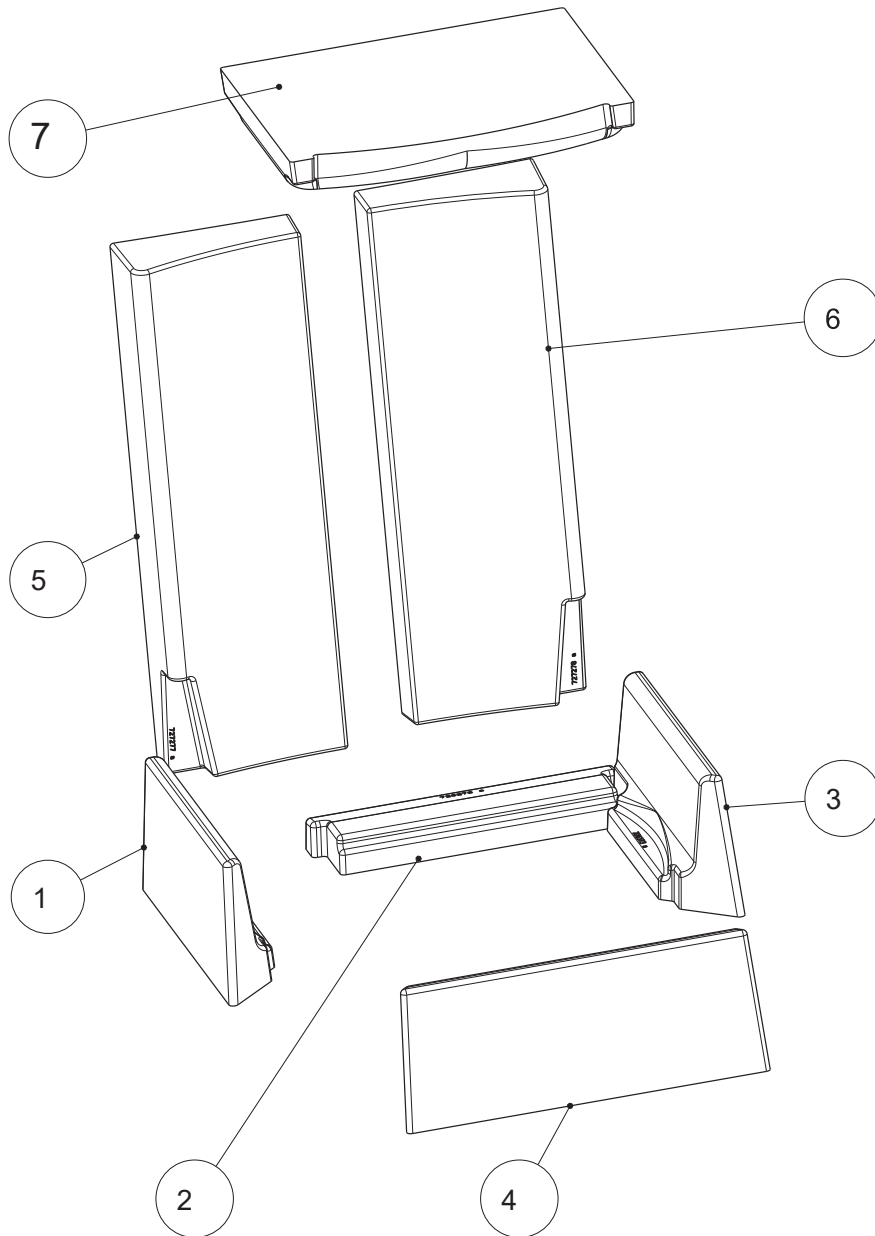

Item no.	Quantity	Item	Article No.
1	1	Keramott floor left	726273
2	1	Keramott floor rear	726276
3	1	Keramott floor left	726373
4	1	Keramott floor front	727274
5	1	Keramott panel rear left	727277
6	1	Keramott panel rear right	727278
7	1	Tension plate	727279

Firebox window

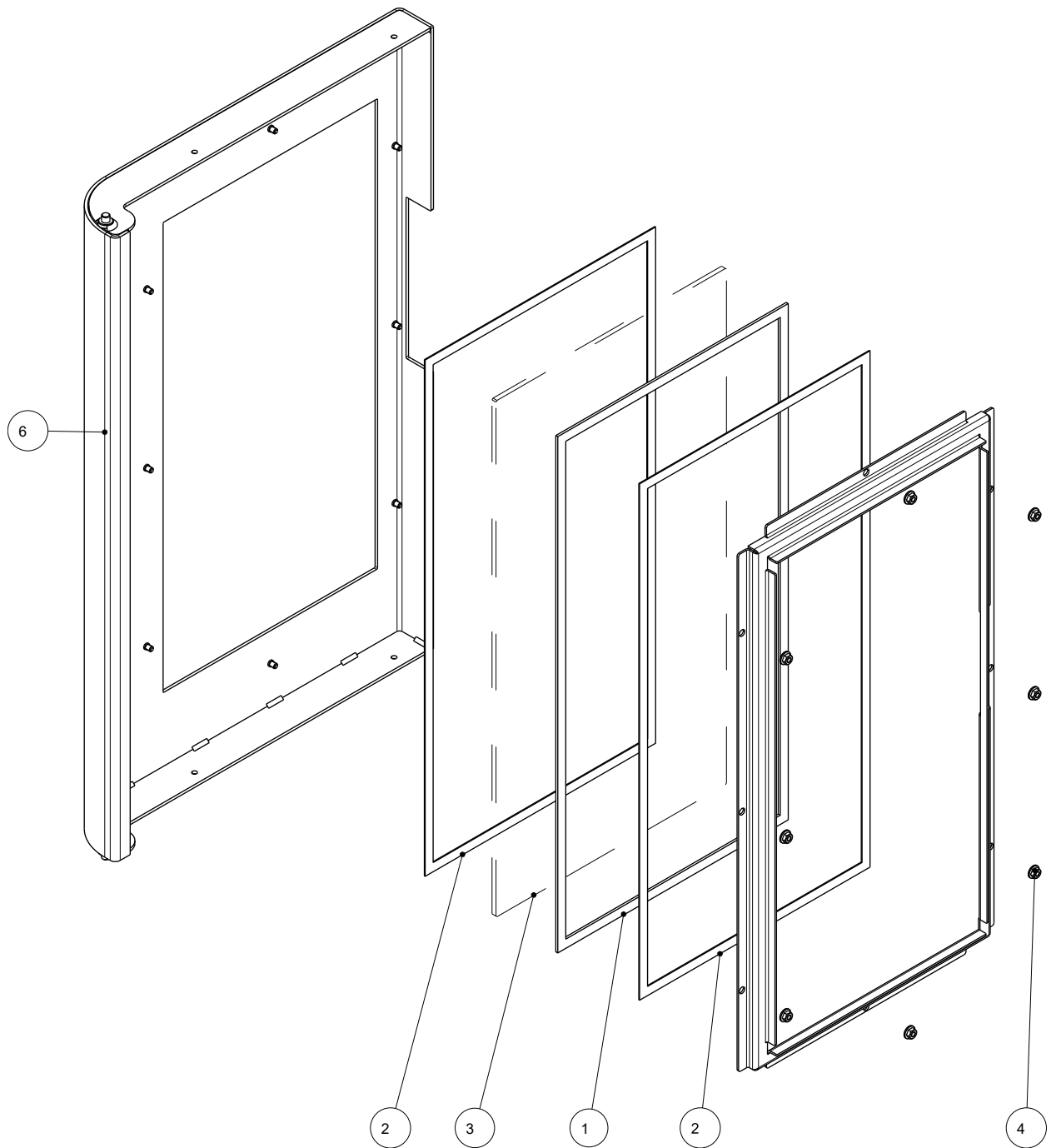

Item no.	Quantity	Item	Article No.
1	1	Gasket 8x2x1600 CULIMETA	710096
2	2	Gasket 8x0.8x1600, self-adhesive CULIMETA	718767 008
3	1	Window glass for firebox window	727258
4	8	Hexagon nut with flange, M4 DIN6923	718739-92
5	1	Bracket - window glass for firebox window	732117-29

18 Dismantling

For correct uninstallation and dismantling of the stove, contact your Austroflamm specialist dealer.

18.1 Removing the rear panel

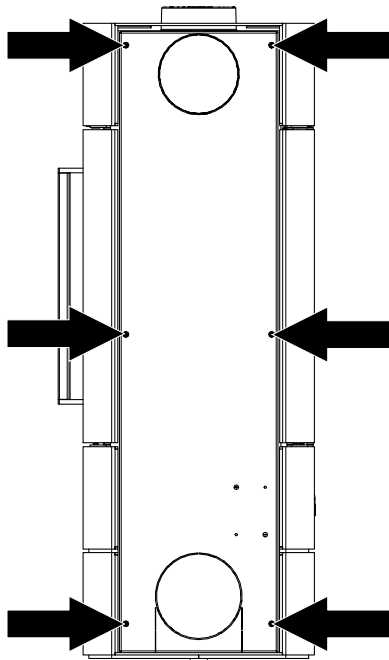

Fig. 40: Loosening the screws

1) Loosen the screws on the rear panel.

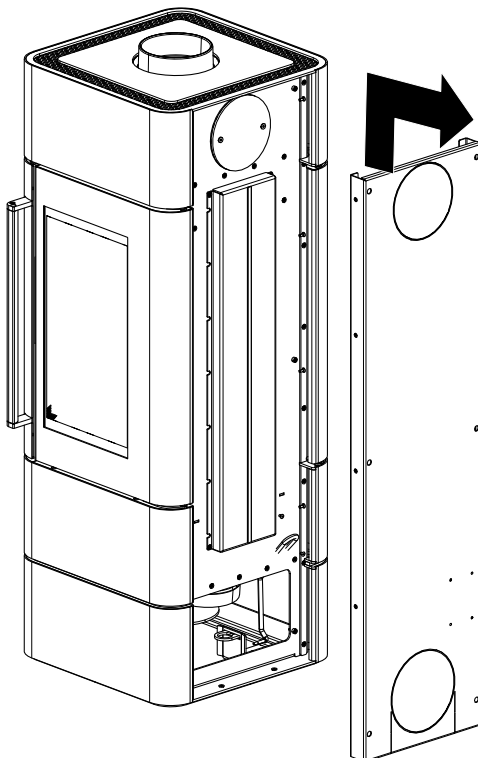

Fig. 41: Detaching the rear panel

2) Then press the rear panel upwards and remove it.

18.2 Removing the door

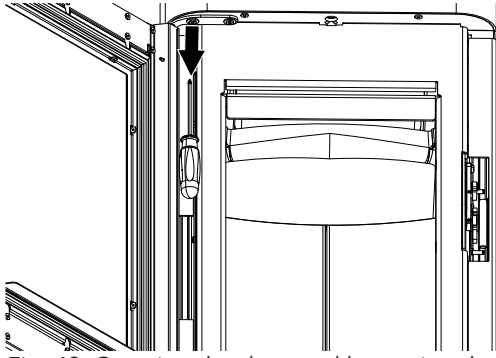

Fig. 42: Opening the door and loosening the screws

1) Open the door and loosen the screws.

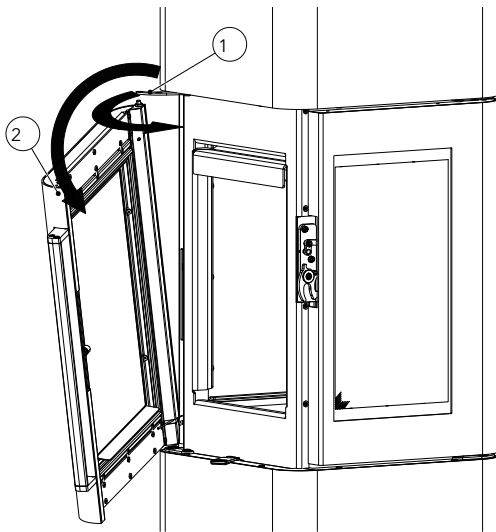

Fig. 43: Unhooking the door

2) Press the hinge plate (1) out and unhook the door (2).

19 Disposal

NOTICE

To dispose of the stove properly, get in touch with the local (possibly municipal) waste disposal company.

NOTICE

We recommend that you remove those components of the stove which have been in contact with fire such as window, combustion chamber, grates, firebox lining (Keramott), ceramic, sensors and baffle plates and dispose of them in the household waste.

NOTICE

For correct uninstallation and dismantling of the stove, contact your Austroflamm specialist dealer.

Electric and electronic components

Remove the electric and electronic components from the appliance by dismantling them. These components must not be disposed of via non-recyclable waste. Disposal should be carried out professionally via the electrical and electronic waste return system.

Keramott

Remove Keramott components. If present, fastening elements must be removed beforehand. Keramott components that have been in contact with fire or flue gas must be disposed of. Reuse or recycling is not possible. Local disposal options must be observed.

Steel sheet

Disassemble steel-sheet components of the appliance by mechanical crushing. If present, remove seals beforehand. Dispose of steel sheet parts as metal scrap. Local disposal options must be observed.

Cast iron

Disassemble cast-iron components of the appliance by unscrewing or flexing them from one another, or alternatively by mechanical crushing. If present, remove seals beforehand. Dispose of the cast-iron parts as metal scrap. Local disposal options must be observed.

Natural stone

Mechanically remove any natural stone present from the appliance and dispose of it as construction waste. Local disposal options must be observed.

Fittings etc. (for water-carrying appliances)

Disassemble the components for carrying water by unscrewing and removing them and dispose of them as metal scrap. Local disposal options must be observed.

Seals (glass fiber)

Mechanically remove the seals from the appliance. These components must not be disposed of via non-recyclable waste, as glass fiber waste cannot be destroyed through burning. Dispose of seals as glass- and ceramic fiber waste (artificial mineral fibers (AMF)). Local disposal options must be observed.

Handles and decorative elements made of metal

If present, disassemble or remove handles and decorative elements made of metal and dispose of as metal scrap. Local disposal options must be observed.

20 Guarantee / warranty

- 1) **Warranty statement:** For your AUSTROFLAMM stove, we guarantee the flawless performance of the body for six years, and of all other steel and cast iron components for two years from the date of first sale.

Steel and cast-iron parts that manifest material- and or processing defects during the guarantee period (warranty case) will be replaced for new parts provided that the warranty case has been asserted to the best of the holder's knowledge within the statutory warranty period. Functional problems with electronic accessories (e.g. AIR+ automatic air control, etc.) shall only justify a warranty claim for the particular accessory.

Our warranty only covers the free delivery of the new parts: work- and travel times are not recorded.

- 2) **Exceptions:** We do not provide a guarantee on wearing parts (e.g. Keramott, seals and grate), surface coatings, varnish, glass and ceramics. In the case of such defects no warranty case has occurred .

When heating up, during operation and when cooling down, your stove may produce some noise (crackling, soft clicking, etc.). This is caused by the various materials expanding and contracting under the influence of temperature in your stove. Noise of this kind does not constitute a warranty claim and do not constitute a warranty claim.

The territorial scope of validity of our guarantee covers Austria, Germany and France. In all other countries, separate conditions of the importer apply to the respective country.

No warranty case occurs if your Austroflamm stove is not located within the territorial scope of validity, which does not change if it is transported or dispatched by Austroflamm."

- 3) **Requirements:** A warranty case shall only then be replaceable if your Austroflamm stove has been operated, maintained, installed and commissioned by a specialist authorized by Austroflamm, all in compliance with the user handbook. For the replaceability of the warranty case the start-up log must be received by Austroflamm within one month at the latest of the initial commissioning. In order to make a claim on the warranty, repairs to your stove must only be carried out by a service engineer authorized by Austroflamm.

The warranty claim is asserted with the invoice and serial number with the Austroflamm specialist dealer via whom the purchase was made. An unjustified warranty claim will be charged back to you.

- 4) **Guarantee:** This guarantee does not affect your statutory warranty rights towards us. Should your Austroflamm stove already be defective at the point of handover, you can always connect us within the framework of the statutory warrant regardless of whether there is a warranty claim or the guarantee is claimed.

21 Data processing

Additional commissioning report in respect of data processing

(please forward together with start up log and this page to info@austroflamm)

The personal data given in the start up log, in particular name, address, telephone number, which are solely necessary and required for the purpose of executing the start up of the product, are collected on the basis of legal authorizations.

Any use of the personal data beyond this and the collection of additional information usually requires the consent of the data subject. You may voluntarily grant such consent in the following section.

If you consent to the appropriate handling of your personal data for the following purposes, please tick this box.

I hereby agree that Austroflamm GmbH and AUSTROFLAMM Service GmbH & Co KG may send me service reminders and offers on other products from Austroflamm GmbH for the purposes of advertising via E-Mail/ SMS/ telephone.

Signature

Date:

The legal instruction can be accessed on the Austroflamm GmbH home page at the following address:
<https://www.austroflamm.com/de/datenschutz>.

22 Start up log

Operator / Customer	Dealer / Engineer
Name	Company
Street	Street
Town and postal code	Town and postal code
Telephone	Telephone
Email	Email

Stove	Working	Comments
Model		
Serial number		
Technology		
Visuals		
Accessories		

On-site conditions	
Type of chimney <input type="checkbox"/> brick <input type="checkbox"/> stainless steel <input type="checkbox"/> firebrick	Flue pipe diameter:
Chimney diameter:	Draft: Actual value: Target value: >12 Pa
Chimney height:	Outside temperature during draft measurement:
Chimney flue - Approved by chimney sweep <input type="checkbox"/> yes <input type="checkbox"/> no	External air supply conduit <input type="checkbox"/> yes <input type="checkbox"/> no
Controlled living space ventilation <input type="checkbox"/> yes <input type="checkbox"/> no	Length:

Instructions for Operator / Customer		
Instructions for handling the appliance explained clearly and comprehensibly	<input type="checkbox"/>	Appliance test heated together with the customer
Guarantee conditions and warranty explained	<input type="checkbox"/>	Cleaning and maintenance interval explained
<input type="checkbox"/> glove <input type="checkbox"/> operating manual handed over	<input type="checkbox"/>	

The customer confirms that the stove has been handed over in a fully functional state and free of defects.

Place, date

Signature Operator / Customer

Signature Technician

Endkontrolle

Final inspection
Controllo finale
Contrôle final

Technische Funktion
technical function / funzione tecnica / fonction technique

Lackierung / paint / vernice / peinture

Sauberkeit / cleanliness / pulizia / propreté

Vollständigkeit / completeness / completo / complet

Geprüft von / checked by / controlled da / contrôlé par

Datum / date / data / date



Typenschild (Duplikat)
Type plate (duplicate)
Targhetta (duplicato)
Plaque signalétique (duplicata)

AUSTROFLAMM GMBH
Austroflamm-Platz 1
A- 4631 Krenglbach

Tel: +43 (0) 7249 / 46 443
www.austroflamm.com
info@austroflamm.com

